

HDU 15/12 Compact Oil Filter

CJC® Offline Fine Filter, Compact Design

APPLICATION

The CJC® HDU 15/12 Compact Offline Oil Filter is used for maintaining clean oil in **(power) transmission, hydraulic and lubrication circuits**. The HDU 15/12 is ideal for removal of **particles, oil degradation products and water** in applications such as:

- Mobile Hydraulic Equipment
- Packaging Machines
- Compact Hydraulic Systems

FUNCTION

The filter pump draws fluid from the system tank (at lowest point) and pumps it through the filter insert. From the centre of the insert the fluid flows through the filter house and returns to the tank.

The pressure drop across the filter insert- and consequently the contaminant absorption of the filter insert- is monitored on the pressure gauge on the filter base.

The filter outlet port is placed on the front of the filter. The filtered fluid should be returned to the tank close to the suction pipe of the main system pump.

Note that the return point should be non-pressurized. Contact us in case this is not possible.

THE FILTER PUMP

The filter pump is a gear pump. Available with standard shaft seal or enclosed magnetic couple. Diesel version only available as magnetic couple. The electric motor can be supplied as AC or DC motors. IP Class: IP 55

FILTER INSERT

The CJC® Filter Inserts consist of several discs bonded together. Depending on the fluid to be filtered, the material is either cellulose or cotton liners.

Main Dimensions

338 x 251 x 336

FILTRATION ABILITY

• Particle Removal

All CJC® Filter Inserts have the following filtration degree:

- 3 µm absolute:

98.7% of all solid particles >3 µm

- 0.8 µm nominal:

50% of all solid particles >0.8 µm

are retained in each pass.

The dirt holding capacity is 0.75 litres of evenly distributed solids.

• Degradation Products

Oxidation products, resin / sludge, and varnish are retained by the cellulose material, which will retain appr. 0.5 kg of oil degradation products.

• Water Removal

The water absorption potential is up to 50% (i.e. 375 mL H₂O) of the total contaminant holding capacity.



The CJC® Compact Offline Oil Filter
HDU 15/12

TECHNICAL DATA

Model		HDU 15/12
Pump flow, per hour (std.)	ltr/gal	20-120 / 5.3-32
Pump inlet pressure, max.	bar/psi	1 / 14.5
Filter Insert 15/12	pcs.	1
Power consumption, aver.	kW	0.06
Pressure drop, max.	bar/psi	1.8 / 26
Oil temperature, max.	°C/°F	80 / 176
Dirt holding capacity, appr.	ltr/gal	0.75 / 0.2
Water absorption capacity	ltr/gal	0.4 / 0.1
Dry weight	kg/lb	13 / 29
Operation weight, wet	kg/lb	15 / 33
Design pressure, filter	bar/psi	4 / 58
Ambient temperature, max.	°C/°F	40 / 104

APPLICABLE FILTER INSERTS

Type	Application for
B:	High flows - (large system fluid volumes)
BG:	High viscosity and large flows
BLA:	Water-based fluids and emulsions *)

*) Does not hold water permanently

HDU 15/12 Compact Oil Filter

CJC® Offline Fine Filter, Compact Design

COMPONENTS

Item	Part
1	Pump
2	Pressure gauge
3	Base
4	Mounting plate
5	Filter housing
6	Top Nut
7	Air vent
8	Spring
9	Spring guide
10	Stay bolt
11	Filter insert
A	Oil inlet 1/2" BSP
B	Oil outlet 1/2" BSP
C	Drain valve 1/4" BSP
D	Air Vent
E	Sampling point

DIMENSIONS

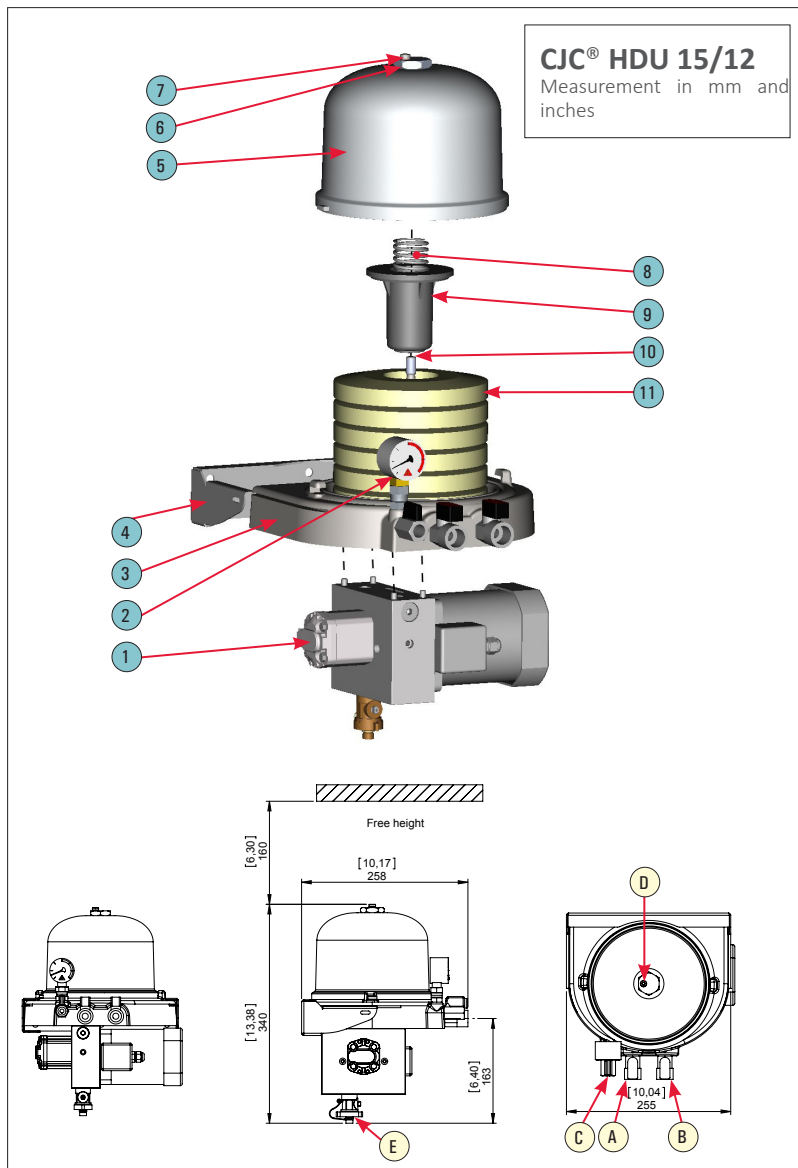

INSTALLATION PRINCIPLE

