

HDU 27/27-108

CJC® Offline Fine Filter

APPLICATION

The **HDU 27/- series of CJC® Offline Fine Filters** are used for the maintenance of fluids for **power transmission, lubrication, cooling and quenching**. The HDU 27/27-108 is ideal for removal of **particles, water, acidity, and oil degradation products**.

FUNCTION

The filter pump draws fluid from the system tank (at lowest point) and presses it through the filter insert. From the centre of the insert the fluid flows through the filter base and returns to the tank.

The pressure drop over the filter- and consequently the contaminant absorption of the filter insert- is monitored on the pressure gauge on the filter top.

The filter outlet port is placed in the filter base. The filtered fluid should be returned to the tank close to the suction pipe of the main system pump.

Note that the return point preferably should be non-pressurized. Contact us in case this is not possible.

THE FILTER PUMP

The filter pump is a CJC® Gear Wheel Pump. The electric motor can be supplied for all standard AC and DC voltages.

FILTER INSERT

The CJC® Filter Inserts consist of several discs bonded together. The material is either cellulose or cotton linters depending on the fluid to be filtered.

OPTIONS

- Preheater
- Drip pan
- Pressure switch
- Tank
- Control Box

FILTRATION ABILITY

• Particle Removal

All CJC® Filter Inserts have the following filtration degree:

- 3 µm absolute:

98.7% of all solid particles >3 µm

- 0.8 µm nominal:

50% of all solid particles >0.8 µm are retained in each pass.

The dirt holding capacity is 4-16 litres of evenly distributed solids.

• Degradation Products

Oxidation products, resin / sludge, and varnish are retained by the cellulose material, which will retain appr. 4-16 kgs of oil degradation products.

• Water Removal

The water absorption potential is up to 50% (i.e. 2,000-8,000 mL H₂O) of the total contaminant holding capacity.



The CJC® Fine Filter
HDU 27/27 P

TECHNICAL DATA

Model HDU		27/27	27/54	27/81	27/108
Pump flow, per hour (std.)	ltr/gal	45 - 4000 / 12 - 1057			
Pump type		PV/P/MZ/GP			
Pump inlet pressure, max.	bar/psi	0.5 / 7			
Filter Insert 15/25	pcs.	1	2	3	4
Power consumption, aver.	kW	0.15-2.2			
Pressure drop, max.	bar/psi	1.8 / 26			
Oil temperature, max. *)	°C/°F	80/176			
Dirt holding capacity, appr.	ltr/gal	4/1.1	8/2.1	12/3.2	16/4.2
Water absorption capacity	ltr/gal	2/0.5	4/1.1	6/1.6	8/2.1
Dry weight	kg/lb	60/132	80/176	97/214	117/258
Operation weight, wet	kg/lb	68/150	97/214	122/269	150/331
Design pressure, filter	bar/psi	4 / 58			
Ambient temperature, max.	°C/°F	40/104			

*) The standard filters are designed for a max. temp. of 80°C / 176°F. Other conditions, please contact us.

APPLICABLE FILTER INSERTS

Type	Application for
A:	Low flows (small system fluid volumes).
B:	Higher flows (large system fluid volumes).
F:	Quenching oils and diesel oils. **)
BLA:	Water-based fluids and emulsions. **)
BLDA:	Glycol-based flame proof hydraulic fluids. **)

**) Does not hold water permanently

HDU 15/25

CJC® Offline Fine Filter

COMPONENTS

Item	Part
1	Sampling point
2	Plug
3	Drain valve
4	Filter plate
5	Relief valve
6	Pump
7	O-ring
8	Filter Insert
9	Spring guide
10	Filter housing
11	Pressure gauge
12	Top nut
13	Vent screw
14	Nut for spring
15	Spring
16	Cover
17	Filter base
18	Stay bolt
19	Plug
A	ø18, Oil inlet
B	ø18, Oil outlet
C	1/2" BSP Drain valve
D	1/4" BSP Vent
E	Sampling point
F	1/4" BSP, Connection for optional pressure switch

DIMENSIONS

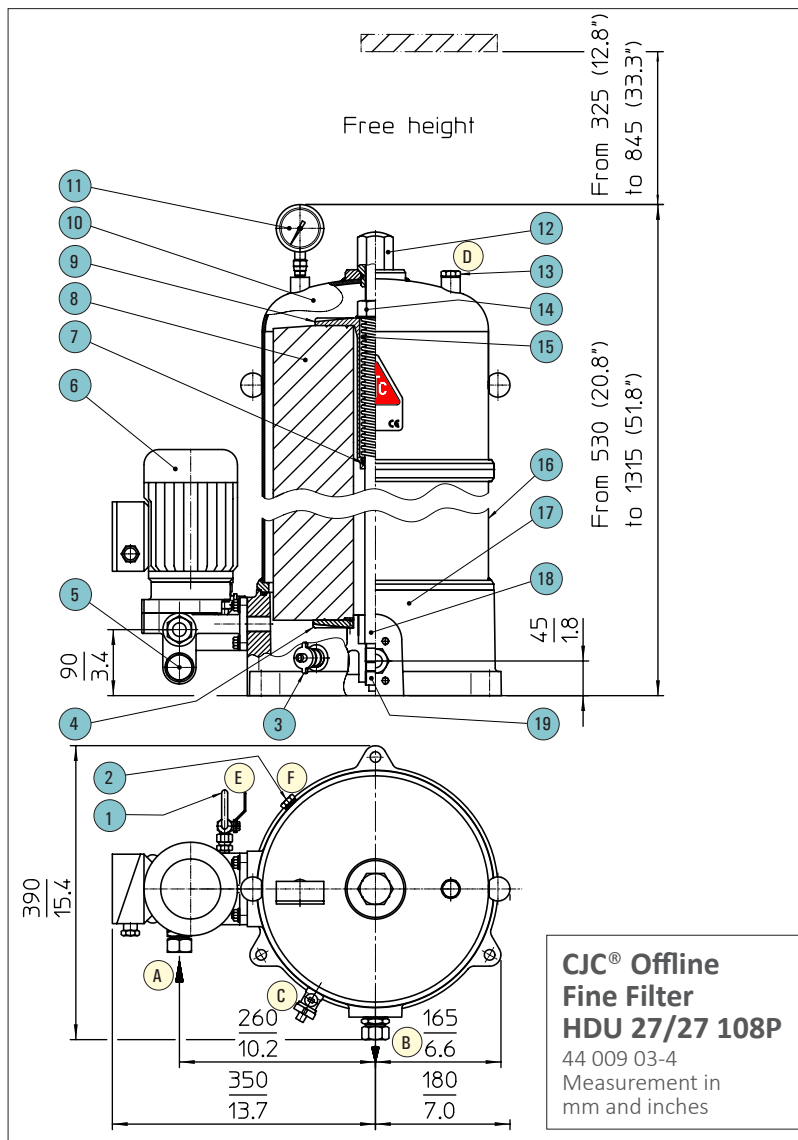

INSTALLATION PRINCIPLE

