

Marine Diesel Purifier

for diesel & gas oil on small and medium size engines

APPLICATION

The **CJC® Marine Diesel Purifier** is a cost effective and efficient alternative for diesel fuel cleaning. Installed between the bunker tank and the day tank the CJC® Diesel Purifier ensures the day tank is always full of clean and dry diesel.

BENEFITS

The **CJC® Marine Diesel Purifier** is a reputed solution for obtaining high quality diesel and gas oil on small and medium consumption engines. With the introduction of the new **CJC® Separator Element PTU3**, we can deliver even higher flow rates with the same high efficiency for both water and particle removal. The requirements for cleanliness as required by injection equipment manufacturers are tightened with the introduction of the Common Rail injection systems. With the CJC® Marine Diesel Purifier installed, these requirements are met with lower operational costs and reduced maintenance cost compared to other purifying equipment. Furthermore, sludge production and related costs will be eliminated. On our new compact units with screw type pump and frequency control, the pump can be detached and placed at a suitable location at a lower deck. The control box is designed for bulkhead mounting, but can be mounted on the purifier itself. The same simple principle as always, but with an integrated flexibility to suit your requirements for engine room design.

WHY

- High quality diesel, clean and dry
- Reduced wear on injection equipment and feed pumps
- Removes organic matters, sludge and bugs from diesel
- Lower emissions
- Simple operation
- Variable flow control
- Easy maintenance
- Reduced power consumption
- Easy installation
- Small footprint

PAYOFF

Whether for retrofit or newbuilding, the CJC® Marine Diesel Purifier will have earned itself within the first year of operation, compared to other means of cleaning the diesel. If installed on newbuildings, the savings on related installation costs compared to other means of cleaning the diesel is substantial. The CJC® Marine Diesel Purifier is uncomplicated to maintain, so vessel crew will not only benefit from operating the unit without much maintenance, also the vessel owner will experience reduced operational costs for maintaining diesel clean and dry.

HOW

The CJC® Marine Diesel Purifier can deliver 1,700-5,100 l/h of clean, dry diesel fuel, enabling operation of up to 22,500 kW engines. With a filtration rating of 3/0,8 micron and a single pass water reduction of 90% or higher, the **CJC® Filter Inserts** and the new **CJC® Separator Element PTU3** reduce the wear on the pumps and nozzles. The simple design means easy maintenance and uncomplicated operation without sludge production. Being, in principle, an offline solution, the quality of diesel delivered to the daytank is unmatched.

OPTIONS

Preheater, separate pump skid, control box mounted on filter, drain tank. The CJC® Marine Diesel Purifier is available in multiple sizes for the individual purpose with 1-3 separator elements and 2-12 Filter Inserts.



The CJC™ Marine Diesel Purifier
PTU 27/54, 3 stay version

TECHNICAL DATA

	Dim.	CJC™ Marine Diesel Purifier	
Pump flow/hour (std.)	ltr/gal	1700/549	5100/1347
Inverter operation		Down to approx. 30% of std. flow	
Power consumption, ave.	kW	0.25 - 0.95	
Pump type		screw spindle, coated	
Pump inlet pressure, max	bar/psi	2.0 / 29	
Pressure control		pressure switch & internal by-pass in pump	
Pressure drop, max	bar/psi	1.8 / 26	
Design pressure, filter	bar/psi	7 / 102	
Filter Inserts, 27/27	pcs.	2-12	
Separator Element, PTU3	pcs.	1-3	
Weight, net	kg/lb	140/309	226/498
Weight, operating, wet & w/o control box	kg/lb	198/437	373/822
Weight, control box	kg/lb	30/66	
Temp. oil, max	°C/°F	60/140	
Temp. ambient, max	°C/°F	45/113	
Water discharger		Automatic	
Capabilities			
Dirt holding capacity approx.	ltr/gal	9/2.4	54/14.4

Marine Diesel Purifier

for diesel & gas oil on small and medium size engines

X	Filter size	a mm/ [inches]	b mm/ [inches]
2	27/54	1300/[51.2]	575/[22.6]
3	27/81	1570/[61.8]	845/[33.3]
4	27/108	1835/[72.2]	575/[22.6]

OPERATIONAL FEATURES

- Compact design
- All steel design
- Skid type unit/ drip pan
- Logic control unit
- LCD display
- Frequency controlled pump
- Flow matches consumption*)
- Screw type pump
- LSF pump (low sulphur fuel)
- Individual separator element drain
- Detachable pump and bracket*)
- Separate control box or integrated control box*)
- Separate pre-heater unit*)
- Fixed inlet/differential connection,
- Preheater unit matches connections
- Remote start/stop
- Inlet/outlet pressure
- Inlet/outlet shut off valves
- Water discharge counter
- Step file drawings
- Centre of gravity data

*) optional features, to be stated upon ordering

SAFETY FEATURES

- Integrated bypass enables emergency operation
- Filter insert change during emergency operation
- Leak detection
- Alarm for excessive water discharge
- Alarm for leaking water discharge valve
- Remote stop/ESD possible

DIMENSIONS

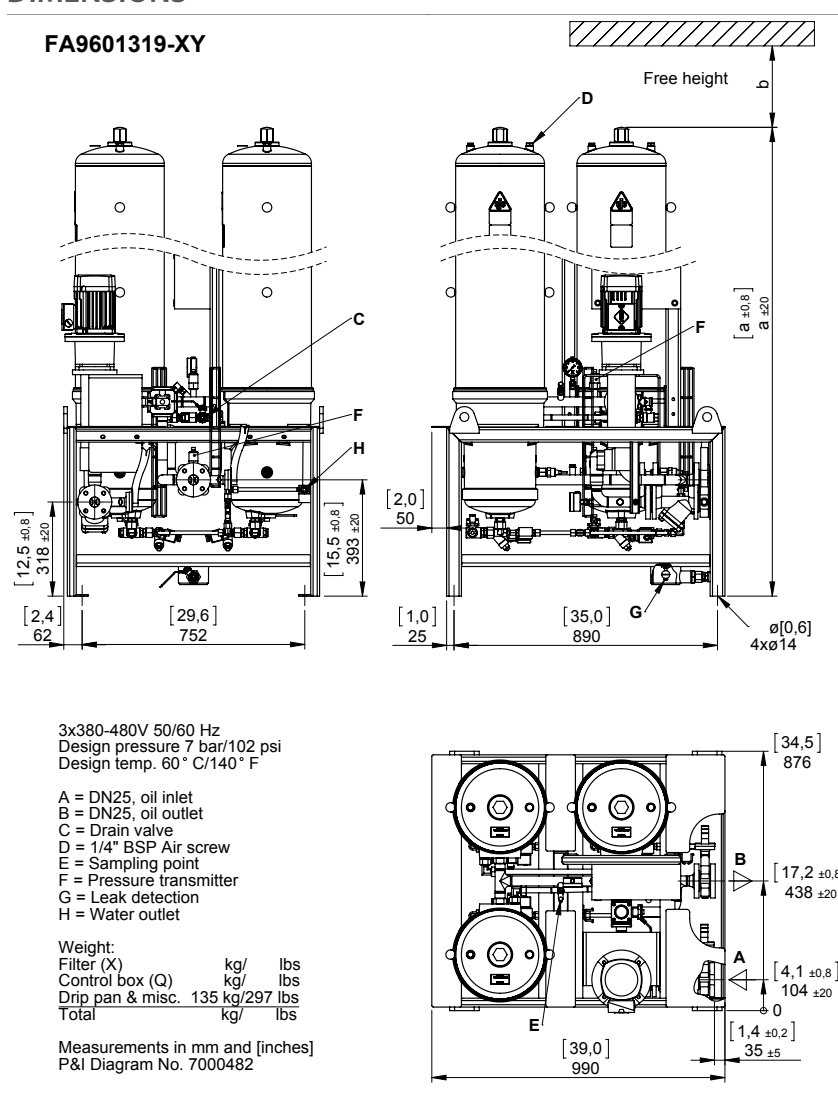

INSTALLATION PRINCIPLE (Diesel Engines)

